



BioCoir[®]

Coconut Fiber Biofilter

Installation Manual



Table of Contents

1.0	Classification Statement	1
2.0	Process Description	2
3.0	Sample Component List	3
4.0	Installation	3
4.1	Septic/Dosing Tank	3
4.2	Effluent Filters with 1/32" Filtration	4
4.3	Filtered Pump Vault	4
4.4	Effluent Discharge	5
4.5	Control Panel/Junction Box	6
4.6	Treatment Mod(s)	7
5.0	Start Up Procedure	9
6.0	Safety	9
Appendix 1	Typical BioCoir System Configuration	10
Appendix 2	Data Plates	11

1.0 Classification Statement

The BioCoir open cell foam biofilter treatment system has been tested, certified, and listed by NSF International as meeting the requirements of NSF/ANSI Standard 40, Class 1 for models bearing the NSF mark.

Table 1 BioCoir Models

Model Number	Mod Type	Notes
Q-ATS-A400-80/20-BC	Anua HDPE	(1) ATS-A400
Q-ATS-A400-80/20-2-BC	Anua HDPE	(2) ATS-A400
Q-ATS-A400-80/20-3-BC	Anua HDPE	(3) ATS-A400
Q-ATS-540-BC-N	Infiltrator IM-540 Tank	(1) IM-540
Q-ATS-1060-BC-N	Infiltrator IM-1060 Tank	(1) IM-1060
Q-ATS-1530-BC-N	Infiltrator IM-1530 Tank	(1) IM-1530



A Series



IM Series



Only mods bearing the NSF® mark are certified NSF/ANSI Standard 40, Class I

2.0 Process Description

Quanics BioCoir is an onsite treatment system utilizing fixed film or packed bed media in an unsaturated environment. The engineered media is housed in a plastic or fiberglass mod. Effluent is sprayed over the media utilizing helical spray nozzles. This engineered delivery system evenly distributes effluent over the media.

BioCoir uses coconut fiber (coir) media. Coir are the fibers that constitute the thick mesocarp, or husk, of the coconut fruit. Coconut fiber is low-cost and a renewable resource. The short-to-medium length fibers are a lingo cellulosic material and by-product of coconut harvesting in many developing nations. The high lignin content of these fibers results in a strong, durable material with high porosity and large surface area. The media properties provide an optimum environment for free air flow and water movement.

Pretreatment of the domestic sewage occurs using a septic tank equipped with an effluent filter, with nominal 1/32" filtration, on the outlet. Alternatively, the Sim/Tech pressure filter or Sim/Tech Nova (No-Vault) filter may be used, in a progressive filtration configuration, to meet the nominal 1/32" filtration requirement. The primary treated effluent then moves into a dosing tank where a pump doses the screened effluent to the treatment mod. The effluent dosing occurs in short, frequent durations over a 24 hour period utilizing a control panel with a repeat cycle timer.

Once sprayed, the effluent moves via gravity down through the media where natural microbiological processes occur that provide high level treatment. After passing through the full depth of media, the effluent travels to the bottom of the mod and the flow is split with 80% back into the treatment stream and 20% to the final dispersal point. The final treated effluent meets the requirements of NSF/ANSI Standard 40, Class 1.



Coconut Fiber Media

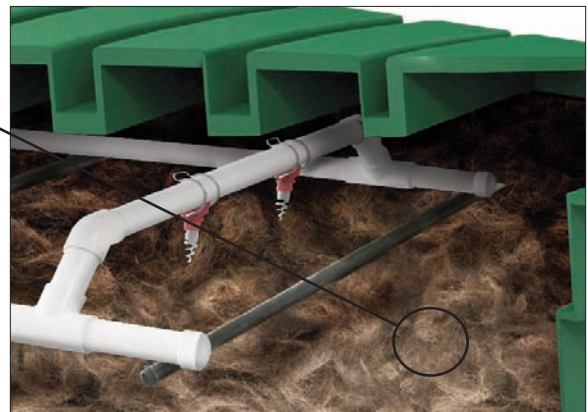

3.0 Sample Component List

The following components list would be for a typical single family home. Individual component parts may vary, depending on the specified configuration.

The list does not include septic or dosing tanks, plumbing, electrical, final dispersal system, and installation. Additional riser sections may be required to bring access to finished grade.

Item	Description	Quantity	
1	Q-EF-BEST-GF10-32	Effluent Filter	1
2	STF-NV06-24-1.25PL	6" dia x 24" tall Nova Filter with Pleated ~3/32" Screen	1
3	Q-P-TE-LG-30GPM-.5HP-115V	1/2HP Effluent Turbine Pump	1
4	Q-PDS-DK-1.25	1.25" Discharge Kit	1
5	Q-PDS-GT-1.25	1.25" Grommet	2
6	Q-AC-FK-4	Float Kit	1
7	Q-AC-FS-SJE-NO-20	Floats	4
8	Q-AC-JB-5	Junction Box	1
9	Q-AC-CP-S-C-T	Simplex Timed Dose Panel	1
10	Q-RB-CTA-26x6	Cast-in Tank Adapter	3 or 4
11	Q-RB-R-26x18	26" x 18" Riser	3
12	Q-RB-L-26	26" Lid	3
13	Q-ATS-A400-80/20-BC	BioCoir Mod	1

4.0 Installation

The BioCoir system must be installed according to these instructions. Any modifications to the system will result in loss of warranty and invalidation of the system's NSF certification. Remove the outer packaging material from the mod(s) prior to installation.

4.1 Septic/Dosing Tank

The tank(s) should be installed level and on a stable base to reduce the possibility of settling. They shall be installed to ensure watertightness and so as to not allow infiltration or exfiltration. The tanks shall be installed to allow gravity flow into each chamber. The inlet and outlet shall be sealed and rendered watertight. Please comply with all regulations and policies per the local regulatory authority.

Riser extensions must be used to bring access above finished grade (figure 1). Under no circumstances shall any access cover(s) be buried.

Backfill the excavation using a material that will settle well around the tanks. Do not use large rocks or heavy clay. Place the material around the tanks in layers, tamping each layer.

Before the installation is complete, the access cover must be in place and the tamper-resistant screws (figure 2) must be installed and properly tightened to prevent unauthorized personnel from gaining entry inside the tank.

Note: The tank must be filled to the outlet/overflow with water after installation to prevent hydrostatic displacement (floating of tanks).

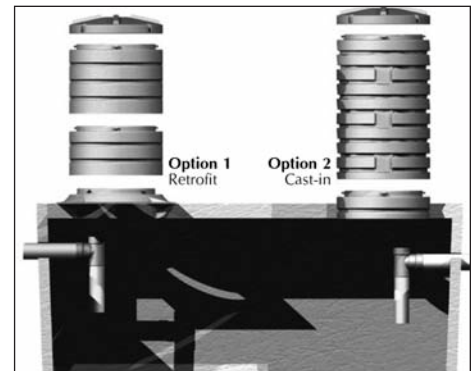

Figure 1



Figure 2

4.2 Effluent Filters with 1/32" Filtration

Note: Alternatively, the Sim/Tech pressure filter or Sim/Tech Nova (No-Vault) filter may be used, in a progressive filtration configuration, to meet the nominal 1/32" filtration requirement.

1. Before installation, dry fit the filter case (figure 3) on the outlet pipe of the primary septic tank to make sure it will be centered under the access opening. If not, solvent weld (glue) additional pipe to the outlet pipe so that the filter case will be centered.
2. Prime and glue the filter case onto the 4" outlet pipe.
3. Prime and glue the filter handle to the top plate of the filter cartridge. Extend the handle, as required, to make it accessible from finished grade (figure 4).
4. After the glue has adequately cured, insert the filter cartridge into the case, making sure the filter cartridge is properly aligned and completely inserted into the case (figure 5).

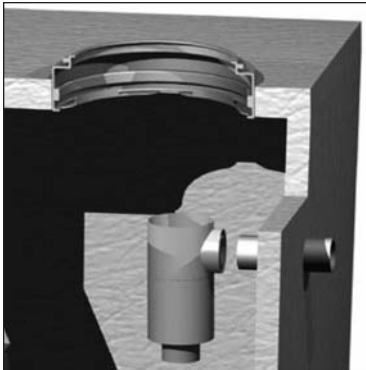

Figure 3

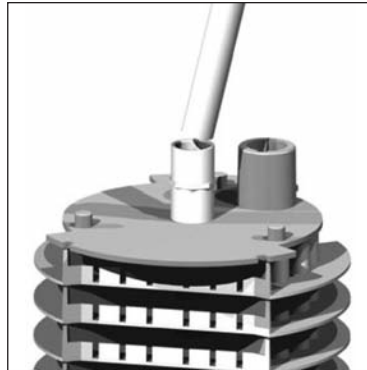

Figure 4

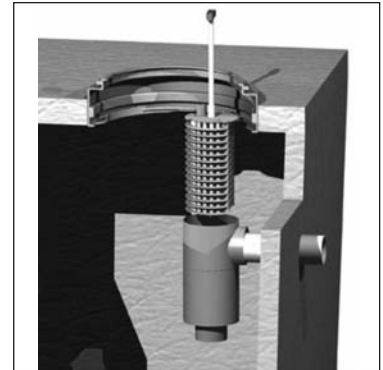

Figure 5

4.3 Filtered Pump Vault

Note: Alternatively, the Sim/Tech pressure filter or Sim/Tech Nova (No-Vault) filter may be used, in a progressive filtration configuration, to meet the nominal 1/32" filtration requirement.

1. Thread 1.5" Schedule 40 PVC pipe through the handles to bridge the access opening in the dosing tank (figure 6).
2. Lower the filtered pump vault through the outlet access opening in the dosing tank and allow it to rest on the tank or access riser (figure 7).
3. Remove the white maintenance plate from the inside of the filtered pump vault. Do not discard. The maintenance plate may be stored inside the access riser.
4. Add additional access risers as needed to bring to finished grade (figure 8).



Figure 6

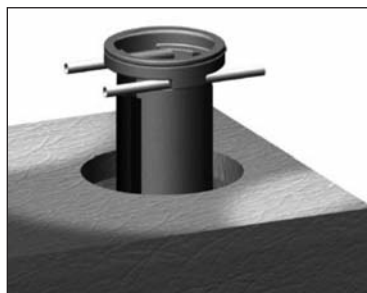

Figure 7

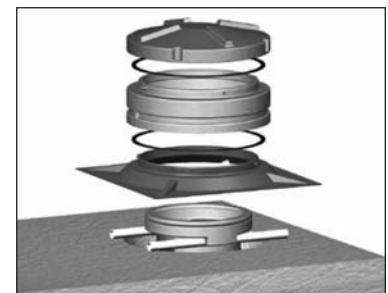

Figure 8

4.4 Effluent Discharge

1. Thread the Schedule 40 PVC threaded male adapter into the discharge of the pump (figure 9). Use Teflon tape or plumbers putty on the threads to insure leak-proof fit. Insert rigid PVC pipe (with primer and glue) into the male adapter (figure 10). This section of PVC pipe may be adjusted to desired height.
 2. Attach the Schedule 40 PVC slip/slip adapter on the rigid PVC pipe coming from the pump (figure 11). Insert the PVC pipe into the slip/slip adapter (with primer and glue) (figure 12).
 3. Cut PVC pipe and attach the union ball valve (union and ball valve may be separate) so that it is located in the middle of the riser and accessible from the top (figure 13). Drill the appropriate sized hole in the riser.
 4. Insert the grommet into the drilled hole. Insert the cut section of PVC pipe through the grommet from outside (figure 15). Lubricant may be necessary. Then, insert the pipe into the discharge side of the union ball valve (with primer and glue) (figure 16). Attach the outlet side of the pipe to the distribution assembly (not provided).
- Optional:** If a check valve is used, drill a 1/8" hole in the discharge above the waterline and below the check valve.



Figure 9



Figure 10



Figure 11

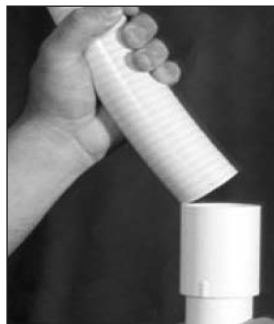

Figure 12



Figure 13



Figure 14



Figure 15



Figure 16

4.5 Control Panel/Junction Box

Note: All wiring and connections must comply with national, state, and local electric codes, as applicable

1. Use the float labels included to identify each float as in figure 17.
2. Determine your normal operating level and float configuration. (figure 17)
3. Mount the floats at appropriate levels on the float tree using the float holders to set the tether length. Be sure that the floats have free-range motion without touching each other or other equipment.

Mounting the Control Panel and Junction Box

1. Determine the mounting location for the panel. If the distance exceeds the length of the float switch cables or pump power cables, use the junction box with liquid-tight connectors to splice the cables. You must use conduit sealant to prevent moisture or gases from entering the panel. (figure 18)
2. Mount the control panel with the mounting devices furnished.
3. Determine conduit entrance locations on the control panel. The controls circuit and pump circuit must have separate incoming power feeds.
4. Drill the proper size holes for the type of connections being used.
(Note: Be sure that the conduit is of adequate size to pull the pump and switch cables through).
5. Attach the cable connectors and/or conduit connectors to the control panel.
6. Connect the pump wires and float switch cables to the proper terminals per the accompanying installation instructions with the control panel.
7. Connect the pump/control and alarm incoming power conductors to the proper position on the terminals. See the schematic and wiring diagram for terminal connections.
8. If using a junction box, determine the mounting location according to local electric code requirements.
9. If mounting the junction box on the inside of the riser, cut the appropriate size hole for conduit in order to adapt to the junction box. Prime and solvent weld the junction box to the pipe.
10. Identify each wire before pulling them through the pipe to the junction box. Make wire splice connections in the junction box using water tight wire nuts or other water tight wire connection.



Figure 17

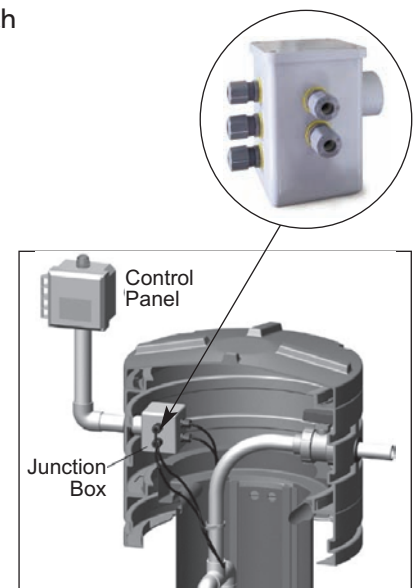
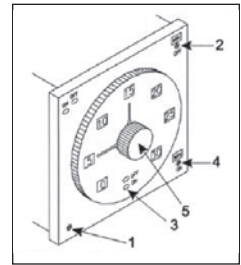

Figure 18

Setting the Timer Example

Refer to the accompanying instructions included with the panel.

1. Determine the pump on and off time and turn the adjustment screw (1) so that the most appropriate range of numbers is visible on the dial face. (see timer setting chart)
2. Adjust the time range selector (2) to the appropriate period. (e.g. minutes)
3. Adjust the outer dial (3) so that the green pointer indicates the off time period required.
4. Adjust the timer range selector (4) to the appropriate period. (e.g. minutes)
5. Adjust the inner dial (5) so that the red pointer indicates the on time period required.
6. The cycle would continue as long as there is enough liquid in the tank to float the low level cutoff switch.



Note: For analog timers, **green** is off and **red** is on.

Typical Timer Settings

1. 500 GPD mod with 96 cycles per day (15 minute total cycle time)
2. Multiply design flow by 5 for dose flow (e.g. 500 GPD x 5 = 2,500 GPD)
3. Divide dose flow by cycles per day for dose gallons (e.g. 2,500 / 96 = 26 gallons)
4. Divide dose gallons by GPM by all spray nozzles (e.g. 26 / 10.2 GPM = 2.6 minutes) (TF-14 spray nozzles = ~2.9 GPM @ 5 PSI and ~3.4 GPM @ 8 PSI)
5. Set on time for 2.6 minutes and off time for 12.4 minutes

4.6 BioCoir Mod(s)

Note: Please refer to additional manufacturer installation requirements for IM series and NS series mods

Each mod arrives pre-plumbed on the inside with only a few simple connections required for installation. 80/20 split mods have an internal divider wall that splits the mod flow 80% and 20%. These models will have a 4" outlet on each end of the mod. The 80% line must be plumbed for recirculation back to the septic tank or dosing tank, depending on configuration.

The 20% outlet line must be plumbed to the gravity drainfield or the drainfield pump tank/chamber. For models with no internal 80/20 divider wall, flow split is achieved by a Gravity Recirculation

Device (see Appendix) or by mod flow segmentation. General guidelines for installing the mod include the following:

1. Locate the mod in an area that provides good ventilation and rainwater run-off. It may be placed directly on the pretreatment tank or it may be located in another area. Prepare an excavation with a width and depth that will allow any and all inlet/outlet connections. Ensure there is gravity flow from the outlet of the mod into the tank or

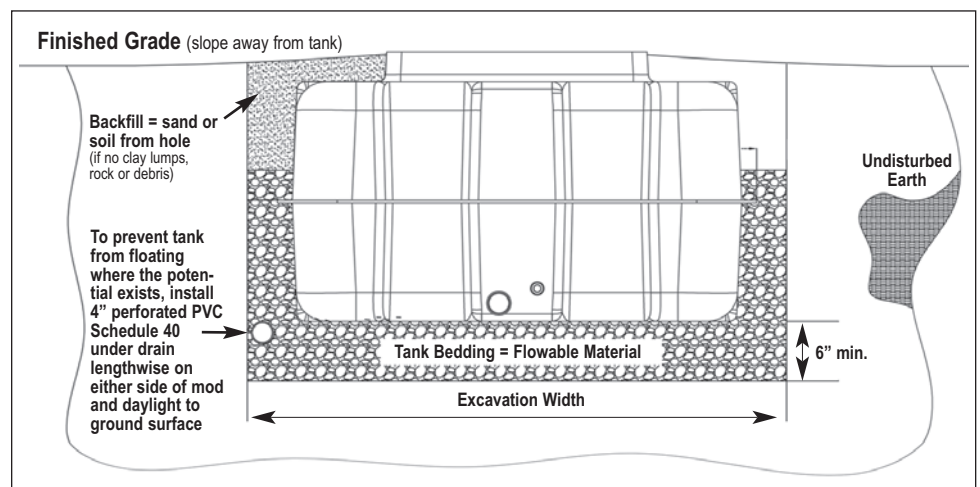

Note: Caution in high water table installations contact Anua at 336.547.9338.

to the gravity recirculation device. The access covers should extend above the final surface grade in such a way to prevent surface water from entering the mod.

2. Using a transit-leveling instrument ensure the mod is placed level and on a stable base. Remove any sharp objects or rocks from the bottom of the excavation or place 4" of sand or fine-grained gradable material, minimum, in the bottom of the excavation.
3. When the bottom of the excavation is graded, bedded with flowalbe material, tamped and level, gently lower the mod into the excavation (figure 20).
4. Connect the pump discharge line to the 1.25" mod inlet hub (figure 21). All piping is Schedule 40 and should be primed and glued.
5. The mod may arrive with the nozzle discharge assembly disconnected to protect during shipping. Attach the nozzle discharge assembly to the corresponding true unions by threading the housing. Hand tighten each true union to prevent water leaks when the system is pressurized.
(Note: Do not glue nozzle assembly!)
6. The nozzle is attached to the discharge assembly via a clamp. Align the opening in the nozzle with the hole in the discharge assembly. Pull the clamp up and over the discharge assembly pipe locking it into place (figure 22).
7. Route and plumb the 4" outlet line marked "80% return" to the septic tank or dosing tank, depending on configuration. The 4" line is gravity return and must be sloped a minimum of 1/8" per foot or per local regulations.
8. On the opposite side of the mod, route and plumb the 4" outlet line marked "20% drainfield" to the drainfield pump tank/chamber. The 4" gravity line must be sloped a minimum of 1/8" per foot or per local regulations.



Figure 20



Figure 21

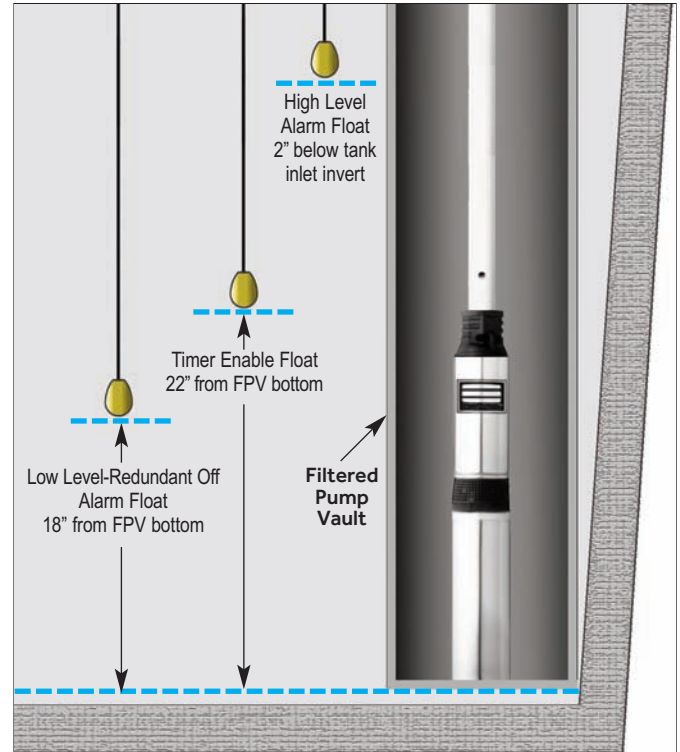

Figure 22

5.0 Start-up Procedure

Once all the connections are made, remove all spray nozzles by unclamping them from the discharge assembly. Turn on the pump to flush any debris from inside the discharge assembly. After flushing, turn off the pump and reinstall the nozzles by locating the nozzle over the discharge hole and sliding the nozzle clamp over the top of the discharge assembly. Turn the pump back on to pressurize the system to check for leaks and set the pressure gauge to, mounted on the nozzle discharge assembly, 5 to 8 psi using the ball valve attached to the assembly. Check all connections for leaks.

If the system is to remain idle for a period of time, please inform the owner that the system is operational. If any mechanical or electrical problems are experienced when attempting start-up, the owner should call the distributor for service and assistance in start-up of the system.



Typical Float Settings

6.0 Safety

Since sewage and effluent contains some level of pathogenic microorganisms, proper respect and care must be given to safety. Whenever you come into contact with sewage or effluent, take proper precautions to avoid direct contact.

Follow these simple safety precautions whenever exposed to the biosolids or effluent in the system:

- Wear disposable rubber gloves when handling contaminated items.
- Always wash with soap and water after handling contaminated items. The use of alcohol-based hand sanitizer is strongly recommended after handwashing.
- Always dispose of scum, rags, trash, debris, or soiled material in a proper waste container.
- If a spill or leak occurs in the yard, flush the area with plenty of clean water and disinfectant. If a spill or leak occurs in the house, clean with a dilute solution of bleach.
- Protect any injury, wound, open cut, etc., from exposure to biosolids or effluent.
- If an illness or disease is suspected to have come from exposure to sewage, get proper medical attention immediately. There are some serious diseases that could be transmitted by contact with sewage—take the proper precautions and be safe!

Appendix 1 Typical BioCoir System Configuration

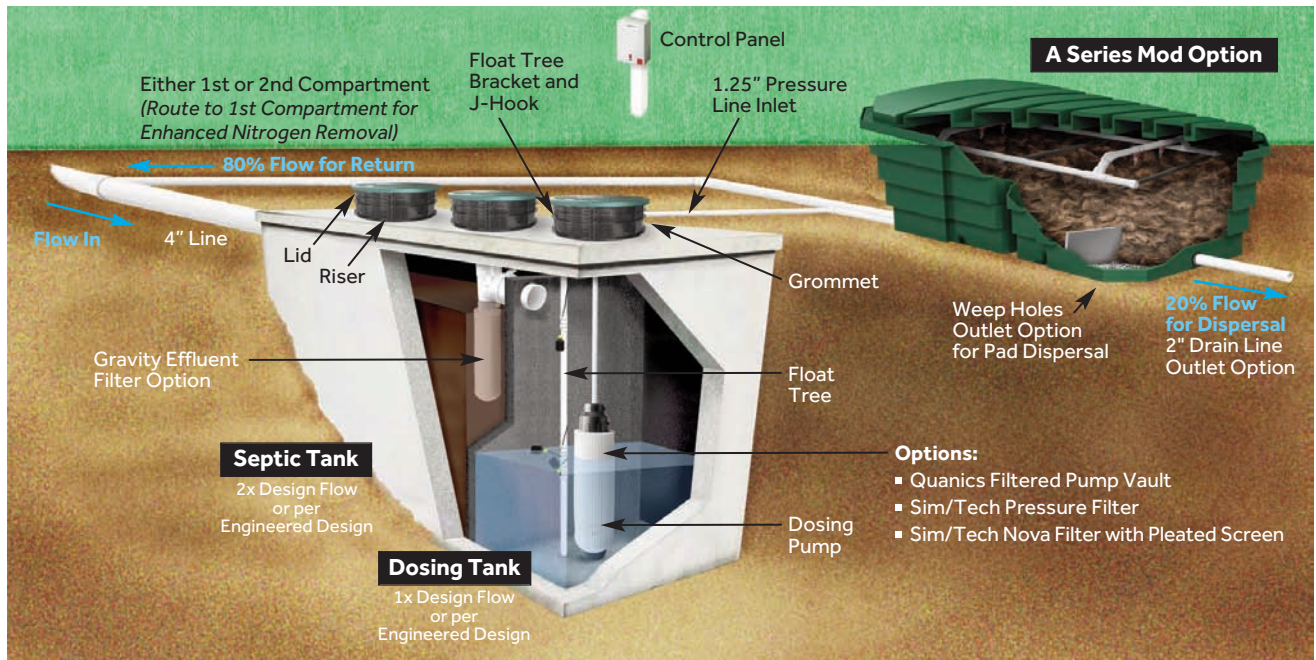

Appendix 2 Sample Serial Numbered Data Plates

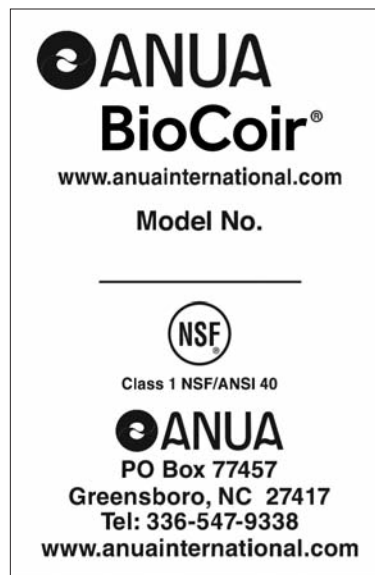



P.O. Box 77457
Greensboro, NC 27417

T 336.547.9338
F 336.547.8559
anuainternational.com

